

IONIQ Hybrid

Emergency Response Guide



Series 1 (2016 ~ 2018)



Series 2 (2019 ~ ~)

HYUNDAI HELP LINE
0800 HYUNDAI (498 632)

⚠ WARNING

- If severe damage causes high-voltage components to become exposed, emergency responders should take appropriate precautions and wear appropriate insulated personal protective equipment.
- Do not attempt to remove the safety plug while standing in the water.
- Never cut or disconnect the high voltage orange cabling and connectors without first disabling the system by removing the safety plug.
- Exposed cables or wires may be visible inside or outside the vehicle. Never touch the wires, cables, connectors, or any electric components before disabling the system, to prevent injury or death due to electrical shock.

Failure to follow any of these instructions may result in serious injury or death by electrocution.

- Do not cut through any component of the Airbag (SRS) system (Supplementary Restraint System)
- SRS components may remain powered and active for up to 3 minutes after the 12V electrical system is shut off or disabled.

Disconnect the battery negative cable and wait for at least 3 minutes before beginning work.

Failure to follow any of these instructions may result in serious injury or death from accidental deployment of the airbag system.

This manual includes information titled as DANGER, WARNING, CAUTION & NOTICE.

These titles indicate the following:

DANGER

DANGER indicates a hazardous situation which, if not avoided, will result in death or serious injury.

WARNING

WARNING indicates a hazardous situation which, if not avoided, could result in death or serious injury.

CAUTION

CAUTION indicates a hazardous situation which, if not avoided, could result in minor or moderate injury.

NOTICE

NOTICE indicates a situation which, if not avoided, could result in vehicle damage.

WARNING

- If severe damage causes high-voltage components to become exposed, emergency responders should take appropriate precautions and wear appropriate insulated personal protective equipment.
- Do not attempt to remove the safety plug while standing in the water.
- Never cut or disconnect the high voltage orange cabling and connectors without first disabling the system by removing the safety plug.
- Exposed cables or wires may be visible inside or outside the vehicle. Never touch the wires, cables, connectors, or any electric components before disabling the system, to prevent injury or death due to electrical shock.

Failure to follow any of these instructions may result in serious injury or death by electrocution.

- Do not cut through any component of the Airbag (SRS) system (Supplementary Restraint System)
- SRS components may remain powered and active for up to 3 minutes after the 12V electrical system is shut off or disabled. Disconnect the battery negative cable and wait for at least 3 minutes before beginning work.

Failure to follow any of these instructions may result in serious injury or death from accidental deployment of the airbag system.

This manual includes information titled as DANGER, WARNING, CAUTION & NOTICE.

These titles indicate the following:

DANGER

DANGER indicates a hazardous situation which, if not avoided, will result in death or serious injury.

WARNING

WARNING indicates a hazardous situation which, if not avoided, could result in death or serious injury.

CAUTION

CAUTION indicates a hazardous situation which, if not avoided, could result in minor or moderate injury.

NOTICE

NOTICE indicates a situation which, if not avoided, could result in vehicle damage.

WARNING

- If severe damage causes high-voltage components to become exposed, emergency responders should take appropriate precautions and wear appropriate insulated personal protective equipment.
- Do not attempt to remove the safety plug while standing in the water.
- Never cut or disconnect the high voltage orange cabling and connectors without first disabling the system by removing the safety plug.
- Exposed cables or wires may be visible inside or outside the vehicle. Never touch the wires, cables, connectors, or any electric components before disabling the system, to prevent injury or death due to electrical shock.

Failure to follow any of these instructions may result in serious injury or death by electrocution.

- Do not cut through any component of the Airbag (SRS) system (Supplementary Restraint System)
- SRS components may remain powered and active for up to 3 minutes after the 12V electrical system is shut off or disabled. Disconnect the battery negative cable and wait for at least 3 minutes before beginning work.

Failure to follow any of these instructions may result in serious injury or death from accidental deployment of the airbag system.

Important Safety Information	1
Introduction	4
IONIQ Hybrid Identification	5
General Vehicle Description	5
- Identifying a Hyundai Hybrid vehicle.....	5
IONIQ Hybrid Main Systems	9
- Main Specifications	9
- Vehicle Components Location	11
- Vehicle Components	13
- Hybrid System Operation	16
- Airbag system (SRS : Supplemental Restraint System)	19
Emergency Procedures	21
- Initial response: Identify, Immobilize and Disable	22
- Extraction Operations	27
- Submersion	29
- Vehicle Fire	30
- High-Voltage Battery Damage and Fluid Leaks	31
Roadside Assistance	
- Towing	32
- To Jump Start the Car (Lithium-ION 12V & Lead Acid Battery 12V Type)	33

Document Purpose

The purpose of this document is to familiarize emergency responders, roadside assistance and the towing industry with the proper methods on handling the Hyundai IONIQ hybrid vehicle in an emergency situation. This guide offers a basic overview of key vehicle systems and provides instructions for dealing with the different types of situations encountered by emergency responders. The emergency response procedures for this vehicle are somewhat similar to a conventional vehicle with additional information provided on dealing with the high-voltage electrical system.

Vehicle Description

As with other Hybrids, the Hyundai IONIQ hybrid uses a conventional petrol powered internal combustion engine paired with a high-voltage electric motor to propel the vehicle.

The high-voltage electrical system is completely self-contained and does not need to be recharged by an external power source such as a charging station through charging port. The high-voltage battery is recharged while the vehicle is being driven. This is accomplished through the use of a generator that produces electricity during driving and braking.



General Vehicle Description

The Hyundai IONIQ five-door hatchback using a chassis developed for eco-friendly vehicles has hybrid, EV and PHEV models. The Hyundai IONIQ hybrid looks very similar to the electric and PHEV models with a few notable exceptions. The safest method is to assume that any IONIQ you respond to is equipped the high voltage system because the IONIQ is exclusive model for eco-friendly vehicle. Using the information provided in this section, responders will be able to differentiate among the three.

Identifying a Hyundai hybrid vehicle

Hybrid badge on boot lid and the Blue Drive badge on side of the vehicle

The Hyundai IONIQ hybrid can be easily identified by the 'hybrid' and the 'IONIQ' badge located on the boot lid and the 'BLUE-DRIVE' badge on the left side of the vehicle.

⚠ DANGER

Electrocution Risk

Badging can become hidden after a crash due to damage to the vehicle. Always be sure to utilize additional methods if identification before determining there is no badge present.



VIN number

The Vehicle Identification Number (VIN) identifies the Hybrid Vehicle with a “C” displayed in the 8th position, as shown in the below drawing.

The VIN is punched on the floor under the passenger seat. The letter C in the 8th character of the VIN indicates that it is a hybrid vehicle with a 1.6 GDi Petrol Engine.

XXXXXXXX CXXXXXXXX

8th digit

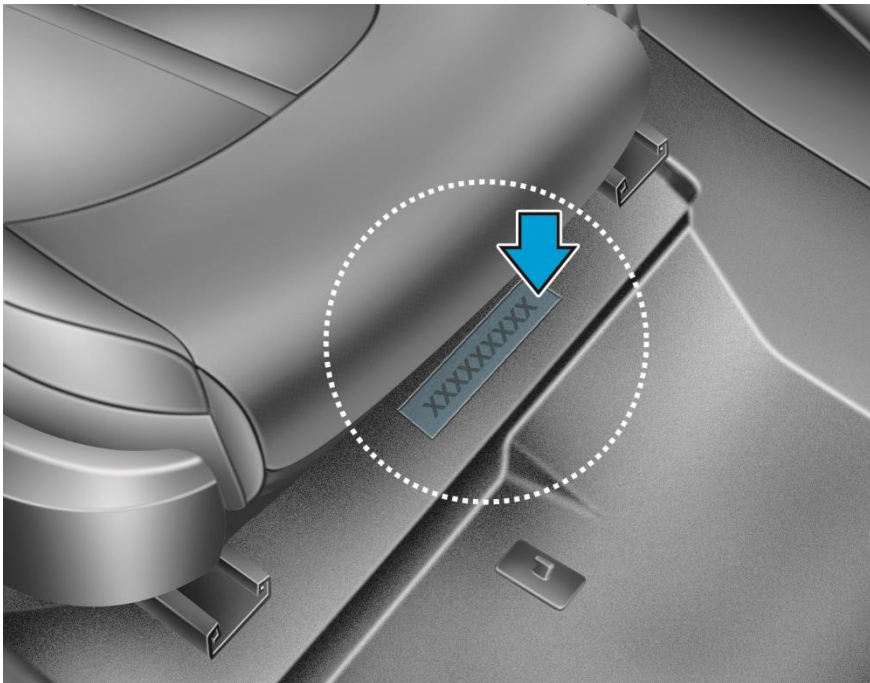

Engine Compartment

The IONIQ hybrid has a plastic engine cover with “Hybrid” clearly shown on it.



Additionally, there are orange colored high-voltage electrical cables in the engine compartment.



⚠ WARNING

Electrocution Risk!

- Never cut or disconnect the high voltage orange cabling and connectors without first disabling the system by removing the safety plug.
- Exposed cables or wires may be visible inside or outside the vehicle. Never touch the wires, cables, connectors, or any electric components before disabling the system, to prevent injury or death due to electrical shock.

Failure to follow these instructions can lead to death by electrical shock.

Vehicle Underside

An orange colored cable covered by the under cover is also visible on the underside of the vehicle. This cable runs from the rear of the vehicle to the engine compartment.



Hybrid Vehicle Cluster Instrument Panel

The Hybrid Vehicle Instrument Cluster Panel displays the hybrid vehicle specific features that identify the IONIQ as a hybrid vehicle.

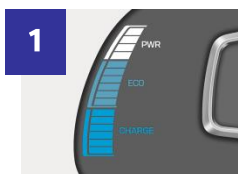

1 : Regeneration brake /ECO/power gauge



2 : SOC(high voltage battery) Indicator indicates the charge state of the high voltage battery.



3 : The **“EV Mode”** Light indicates the vehicle is in EV mode



4 : The **“Ready”** Light indicates the vehicle is ready for driving.

Cluster for Hybrid Entry Model



Cluster for Hybrid Elite Model

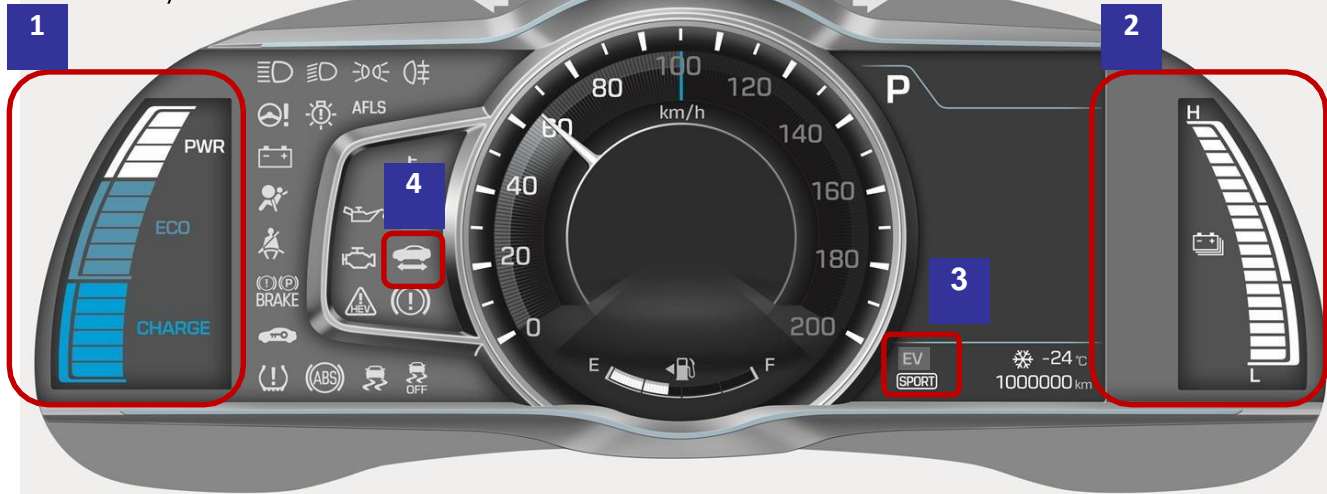

Main Specifications

Item		Electric
Engine	CC	1.6L GDI Hybrid Engine
Transmission	Type	6 Speed Dual Clutch Transmission
Fuel Tank	Capacity	45L
Inverter	Input Voltage	200 – 310 V
Electric Motor	Type	Permanent Magnet Synchronous Motor
	Max. Output (kW)	35
	Max Torque (Nm)	170
High Voltage Battery	Type	Lithium-ion polymer
	Rated Voltage (V)	240
	Capacity (Ah) / Energy (kwh)	6.5 / 1.56
	Number for Packs (Cell / Module)	64 CELL / 4 MODULE
	Weight (kg)	Approx 15

WARNING

Electrocution Risk!

- Never cut or disconnect the high voltage orange cabling and connectors without first disabling the system by removing the safety plug.
- Exposed cables or wires may be visible inside or outside the vehicle. Never touch the wires, cables, connectors, or any electric components before disabling the system, to prevent injury or death due to electrical shock.

Failure to follow these instructions can lead to death by electrical shock.

Vehicle Components Location

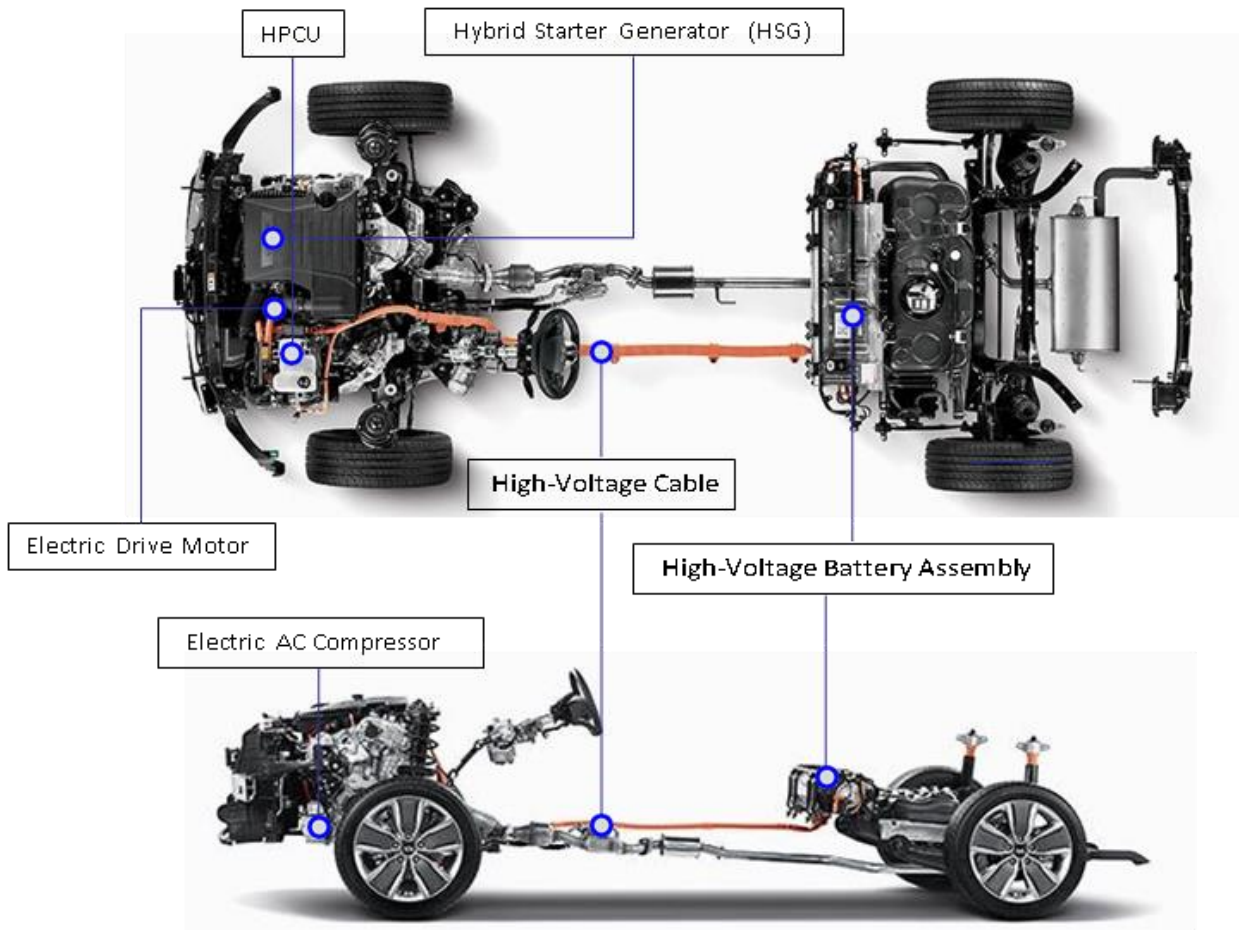

HPCU	Hybrid Power Control Unit (Inverter + LDC + HCU)
LDC	Low Power DC-DC Converter (Charge 12V supplementary Battery)
Inverter	DC → AC (from battery to traction motor) AC → DC (charge using regenerative braking)
Motor	When current flows through the coil, it generates a rotating magnetic field and generates motor torque.
High voltage battery	Supplies electric energy to traction motor and stores generated electric energy.

WARNING

Electrocution Risk!

- Never cut or disconnect the high voltage orange cabling and connectors without first disabling the system by removing the safety plug.
- Exposed cables or wires may be visible inside or outside the vehicle. Never touch the wires, cables, connectors, or any electric components before disabling the system, to prevent injury or death due to electrical shock.

Failure to follow these instructions can lead to death by electrical shock.

Vehicle Components

12V Auxiliary Battery

The 12V Auxiliary Battery is located in the right hand side of the boot and is accessed by removing a small cover. This battery powers all of the standard electronics like radio, air conditioner, etc. It also supplies current to the high-voltage system relays, which control the flow of high-voltage current.

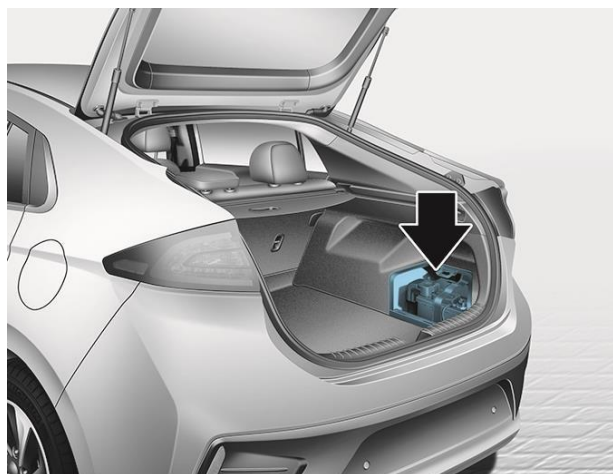

High-Voltage (HV) Battery

The Lithium-ion Polymer HV battery contains a gel electrolyte and is made up of 64 - 3.75V cells wired in series for a nominal voltage of 240V with 6.5 Ah of capacity. The battery is located under the rear seat.



Air Conditioning Compressor

The Air Conditioning Compressor is mounted to the engine directly below the HSG. It is also powered by the high-voltage system, so its electrical connection via an orange HV cable is easily noticeable as well.



Hybrid Power Control Unit (HPCU)

The Hybrid Power Control Unit (HPCU) assembly consists of three components : a Hybrid Control Unit (HCU), an Inverter (Motor Control Unit (MCU)) as well as a Low-voltage DC-DC Converter (LDC). The HPCU assembly contains capacitors which take about 5-10 minutes to discharge after the high-voltage system is shut down.

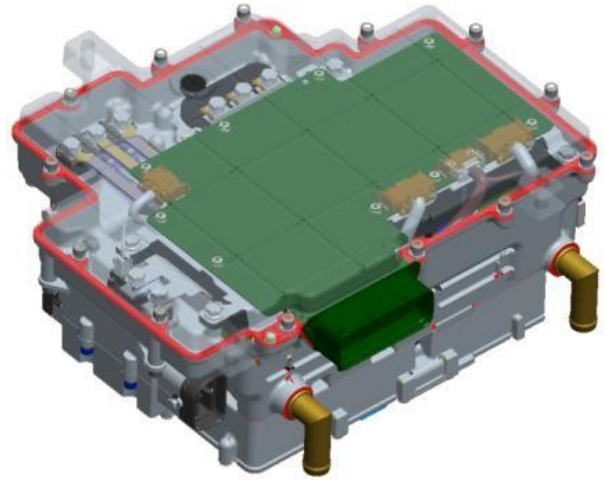

Hybrid Drive Motor

Mounted between the engine and transmission, the Electric Drive Motor is used for vehicle propulsion. During deceleration or braking, it acts as an alternator and charges the HV battery by converting the vehicle's kinetic energy into electrical energy



Hybrid Starter Generator (HSG)

The HSG is mounted to the front of the engine near the intake manifold. It cranks the engine or starting and acts as a generator when the HV battery needs charging. As this is one of the major components of the HV system, its electrical connection is clearly visible via an orange HV cable.

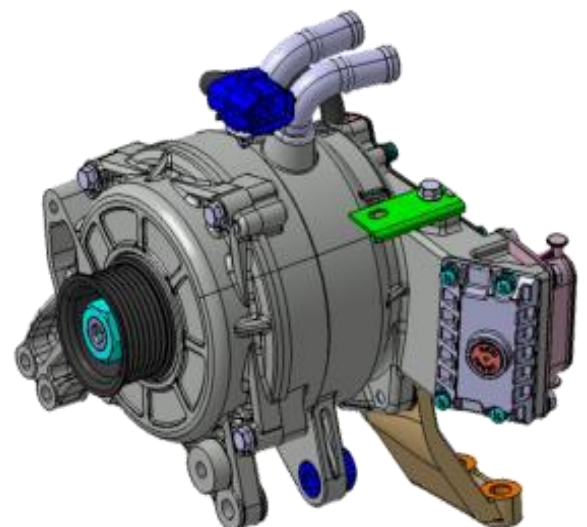

High-Voltage Cabling

The high-voltage cabling in the IONIQ hybrid is orange per the SAE standard. These cables run from the rear of the vehicle where they connect to the HV battery up to the front of the vehicle where they connect to the Electric Drive Motor and other HV components.



⚠ WARNING

Electrocution Risk!

- Never cut or disconnect the high voltage orange cabling and connectors without first disabling the system by removing the safety plug.
- Exposed cables or wires may be visible inside or outside the vehicle. Never touch the wires, cables, connectors, or any electric components before disabling the system, to prevent injury or death due to electrical shock.

Failure to follow these instructions can lead to death by electrical shock.

Hybrid System Operation

The IONIQ Hybrid can be propelled by either the petrol engine or the Electric Drive Motor, or a combination of both.

Charging of the high-voltage battery is done through regenerative braking during deceleration or by obtaining power from the HSG.



WARNING

Electrocution Risk!

- Never cut or disconnect the high voltage orange cabling and connectors without first disabling the system by removing the safety plug.
- Exposed cables or wires may be visible inside or outside the vehicle. Never touch the wires, cables, connectors, or any electric components before disabling the system, to prevent injury or death due to electrical shock.

Failure to follow these instructions can lead to death by electrical shock.

High-Voltage Electrical Isolation

Unlike the 12V electrical system that is grounded to the vehicle's chassis, the IONIQ hybrid's high-voltage electrical system is designed to be isolated from the vehicle.

Regulation of High-Voltage Electrical Current

Current from the High-Voltage Battery is controlled by the Power Relay Assembly (PRA), which consists of Positive and Negative Main Relays, a Pre-charge Relay, Pre-charge Resistor, and the Battery Current Sensor. The PRA is mounted front side of the High-Voltage Battery Pack Assembly and controls the high-voltage power circuit between the High-Voltage Battery and the Electric Power Control Unit.

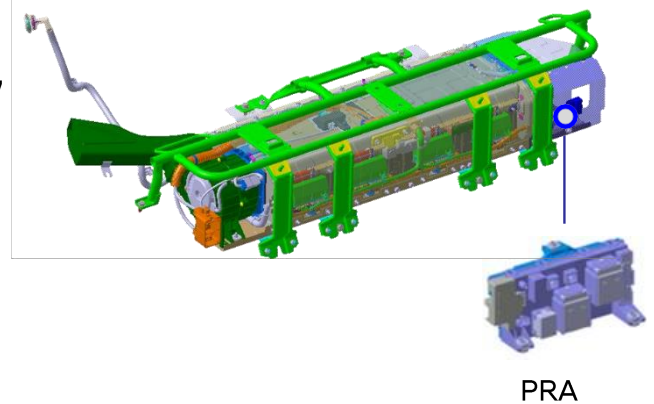

High-Voltage Safety System

There are multiple safety systems incorporated into the IONIQ hybrid. The system that protects the High-Voltage Electrical System is called the Battery Management System (BMS). The BMS is located inside the Power Relay Assembly and measures several parameters to maintain the optimal performance of the High-Voltage Battery. It controls the battery cooling fan to ensure proper battery operation. In addition, if a system fault occurs, the BMS turns off the PRA to protect the system.

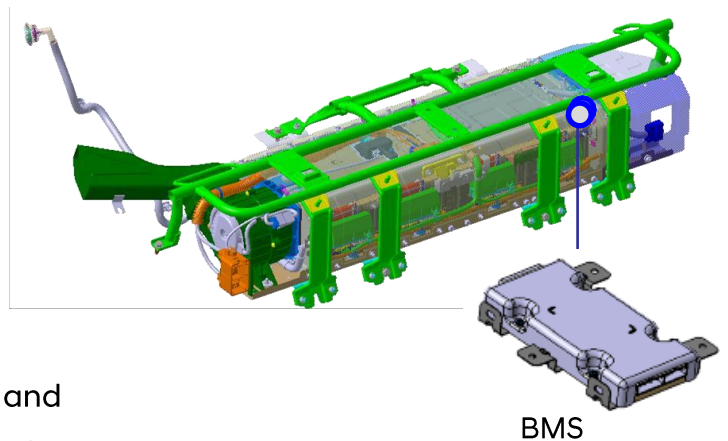

Airbag system (SRS : Supplemental Restraint System)

Airbag

Seven airbags are installed in the IONIQ electric as shown below. Before starting any emergency procedure, make sure the vehicle ignition is turned off, disconnect the negative cable from the 12V auxiliary battery to prevent accidental deployment of airbags.



* The actual air bags and seats in the vehicle may differ from the illustration

Number	Name	Location
1	Driver's front airbag	Driver side
2	Passenger's front airbag	Passenger side
3,4	Side airbag	Driver / Passenger side
5,6	Curtain airbag	Driver / Passenger side
7	Knee airbag	Driver side

Seat Belt Pretensioners

The IONIQ hybrid is equipped with seat belts with pretensioners. When the seat belt pretensioners are activated in a collision, a loud noise may be heard and fine dust, which may appear to be smoke, may be visible in the passenger compartment. These are normal operating conditions and are not hazardous. The seat belt pretensioner assembly mechanisms may become hot during activation, and may need several minutes to cool after they have been activated.

Sensors and Control Module

The airbags and pretensioners are managed by the SRS Control Module, or SRSCM, which is located below the front of the center console. In addition, there are four side impact sensors : two conventional accelerometer sensors in the B-pillars, and two pressure sensing sensors inside of the front door modules. Their locations are illustrated in the image below.

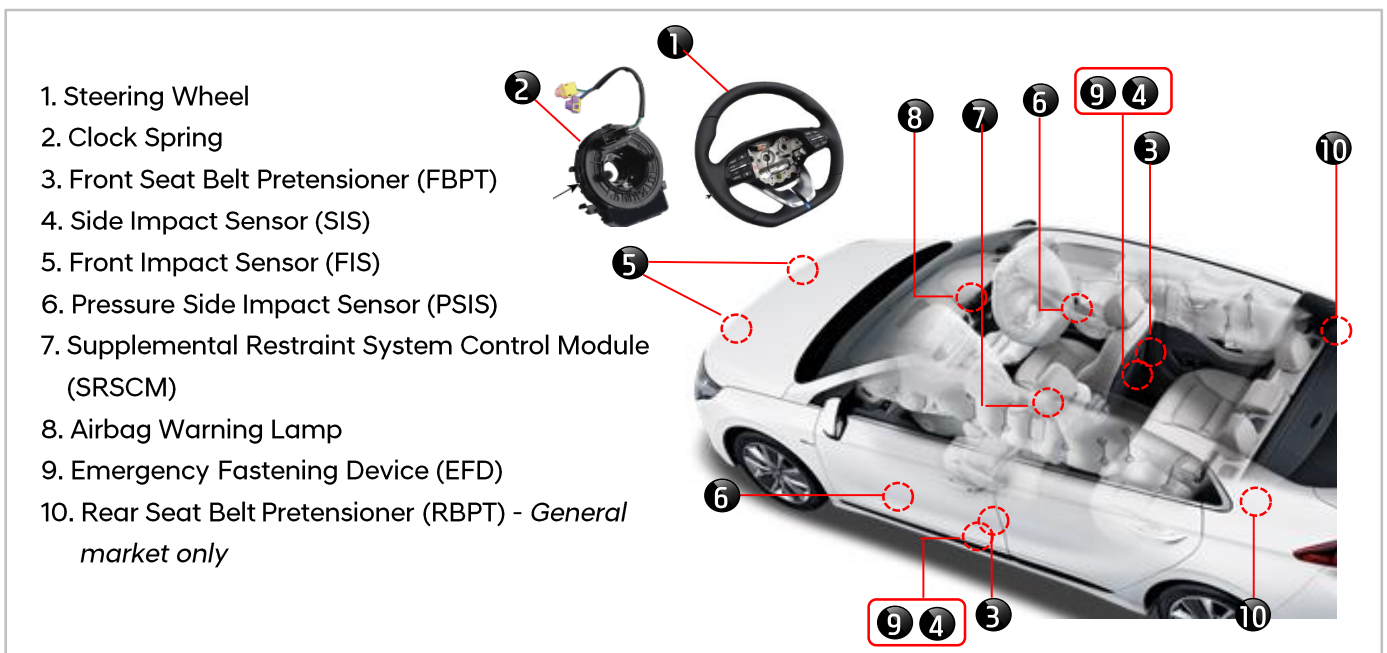

⚠ WARNING

- Do not cut through any component.
- SRS components may remain powered and active for up to 3 minutes after the 12V electrical system is shut off or disabled. Disconnect the battery negative cable and wait for at least 3 minutes before beginning work.

Failure to follow any of these instructions may result in serious injury or death from accidental deployment of the airbag system.

Initial Response

The following procedures should be used whenever you are dealing with a IONIQ electric at an emergency scene. All other operations should be consistent with your department's standard operating procedures or guides. Electric vehicles damaged by a crash may have compromised high voltage safety systems and present a potential high voltage electrical shock hazard. Exercise caution and wear appropriate personal protective equipment (PPE) safety gear, including high voltage safety gloves and boots. Remove all metallic jewelry, including watches and rings.

Identify

When dealing with a IONIQ at the scene of an accident, emergency responders should always assume that it is a electric / hybrid model until it can be proven otherwise using the identification features outlined in this ERG. External badging will usually be the first clue but it can often be hidden by damage caused in a crash. Always be sure to inspect multiple sides of the vehicle as well as using the clues found under the bonnet and in the interior of the vehicle.



Immobilise

The next step is to immobilise the vehicle to prevent any accidental movement that can endanger the emergency response personnel and any crash victims. Since the IONIQ hybrid doesn't have an engine, there will be instances where the vehicle appears to be off because of the absence of engine noise. When in its "ready" mode, the vehicle can move almost silently using the electric motor. Responders should approach the vehicle from the sides and stay away from the front or rear as they are both potential paths of travel. Instructions for immobilizing the vehicle are shown below.



Chock the Wheels



Engage Parking Brake

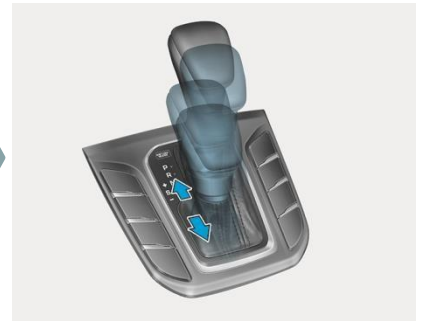

Position the shift lever in park (P)

Disable

The final step in the initial response process, conducted after the vehicle is secured to prevent movement, is to disable the vehicle, its SRS components and the high voltage electrical system. To prevent current flow through the system, use one of the following procedures to disable the vehicle.

Disabling the system – Smart Key System and “POWER” START/STOP BUTTON

1. Check the status of the READY light on the instrument panel. If the READY light is illuminated, the vehicle is on. (Refer to page 6)
 - a) If the READY light is NOT illuminated, the vehicle is off, Do not push the “POWER” START/STOP button because the vehicle may restart.
 - b) To turn off the system, put the shift lever in the P (Park) position and press the POWER button beside a shift lever.

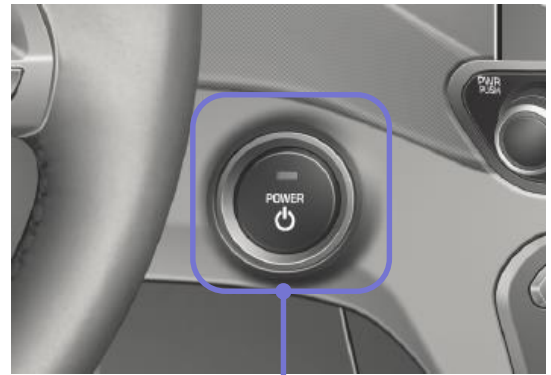

“POWER” START/STOP Button

Without depressing the brake pedal

Pressing POWER button	Button Position	Vehicle condition
	OFF	Off
One time	ACC	Electrical accessories are operational.
Two times	ON	The warning lights can be checked before the vehicle is started.
Three times	OFF	Off

Depressing the brake pedal while a shift lever is in the P (Park) position

Pressing POWER button	Button Position	Vehicle condition
	OFF	Off
One time	-	Ready to drive

2. Before disconnecting the 12V battery, move the smart key at least 2 meters away from the vehicle to prevent accidental restart. For IGN Key type remove from the Ignition barrel.



Smart Key

3. Disconnect the negative (-) 12V battery cable (A), located in the motor compartment, to further prevent the risk of accidental restart.

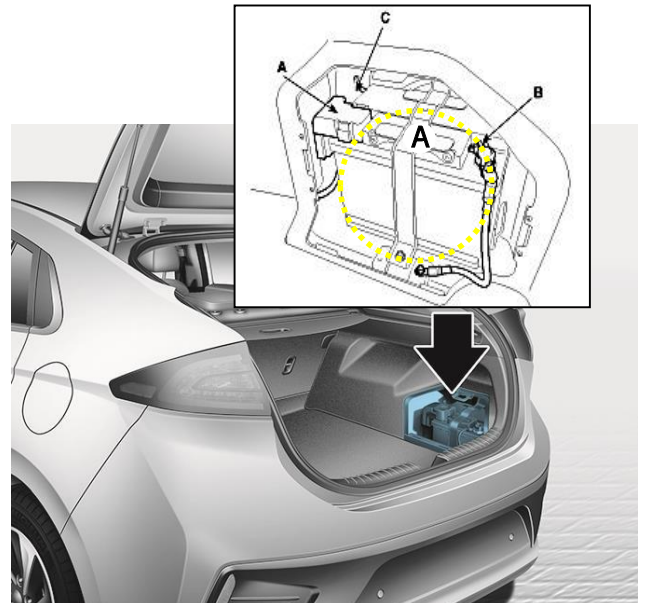

NOTICE

If necessary, lower the windows, unlock the doors and open the boot as required, before disconnecting the 12V battery. Once the 12V battery is disconnected, power controls will not operate.

4. Use the following procedure to remove the safety plug and disable the high voltage battery:

a) Remove the safety plug cover (A) located under the right rear seat.



b) Remove the safety plug using the following procedure :

①: Unlock → ②, ③: Release → ④: Remove

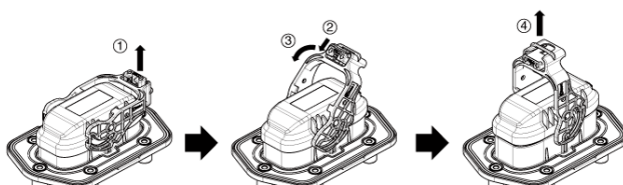

Disabling the system – IG Relay Removal (Alternate Method)

1. Open the bonnet.

2. Remove the motor compartment fuse box cover.

3. In the event the vehicle cannot be disabled using the “Power” START/STOP Button, pull the IG1, IG2 fuses or relays from the motor compartment room fuse box. If the IG fuses cannot be located, pull out all the fuses and relays in the fuse box.

4. Disconnect the negative (-) 12V battery cable (A), located in the motor compartment, to further prevent the risk of accidental restart.

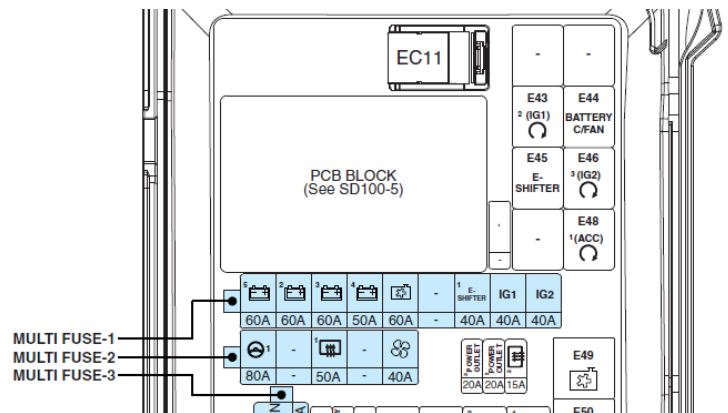
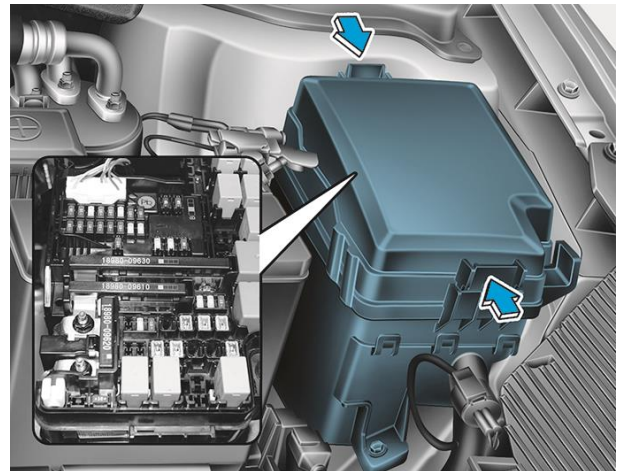

motor compartment fuse box

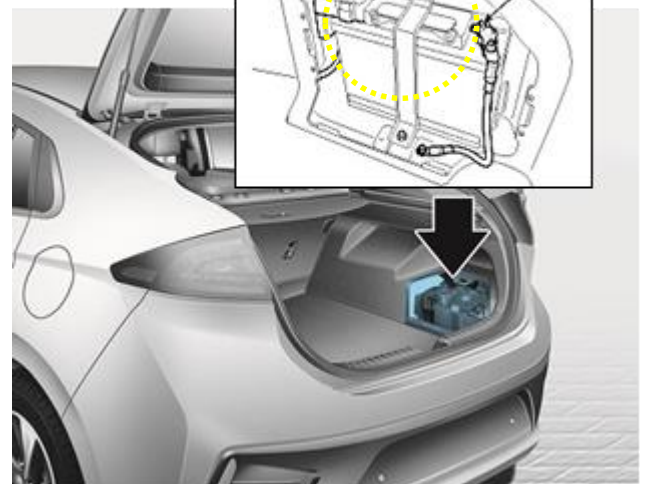
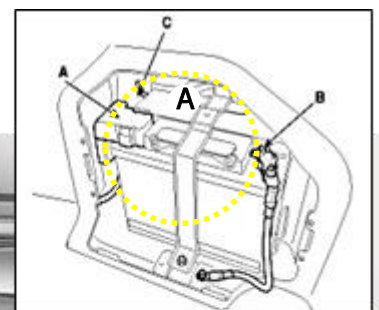

NOTICE

If necessary, lower the windows, unlock the doors and open the boot as required, before disconnecting the 12V battery. Once the 12V battery is disconnected, power controls will not operate.

5. Use the following procedure to remove the safety plug and disable the high voltage battery:

a) Remove the safety plug cover (A) located under the right rear seat.



b) Remove the safety plug using the following procedure :

①: Unlock → ②, ③: Release → ④: Remove

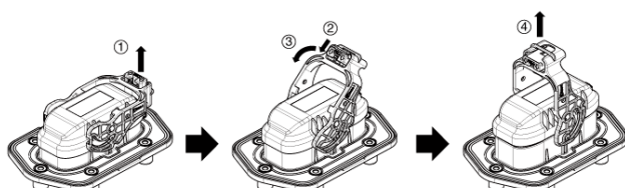

If both methods of disabling system are unsuccessful, the vehicle is not secured from accidental deployment of airbags and electric shock from high-voltage components.

⚠️ WARNING

Electrocution Risk!

- Before engaging in emergency response procedures, ensure the vehicle is disabled and wait for more than 5 minutes to allow the capacitor in the high voltage system to discharge to avoid electrocution.
- Exposed cables or wires may be visible inside or outside the vehicle. To prevent injury or death due to electrical shock, never touch the wires or cables before disabling the system, to prevent injury or death due to electrical shock.

Failure to follow any of these instructions may result in serious injury or death by electrocution.

⚠️ WARNING

Explosive Risk!

- Do not cut through any component of the Airbag (SRS) system. (Supplementary Restraint System)
- SRS components may remain powered and active for up to 3 minutes after the 12V electrical system is shut off or disabled. Disconnect the battery negative cable and wait for at least 3 minutes before beginning work.

Failure to follow any of these instructions may result in serious injury or death from accidental deployment of the airbag system.

Extraction Operations

The extrication operations for the IONIQ Hybrid are similar to the conventional vehicle. However, the first responder should pay special attention when they extract occupants in the vehicle. Before extrication operations, the first responders should carry out “Initial Response: Identify, Immobilize and Disable” procedure from Page 22 ~ 26.

Vehicle Stabilisation



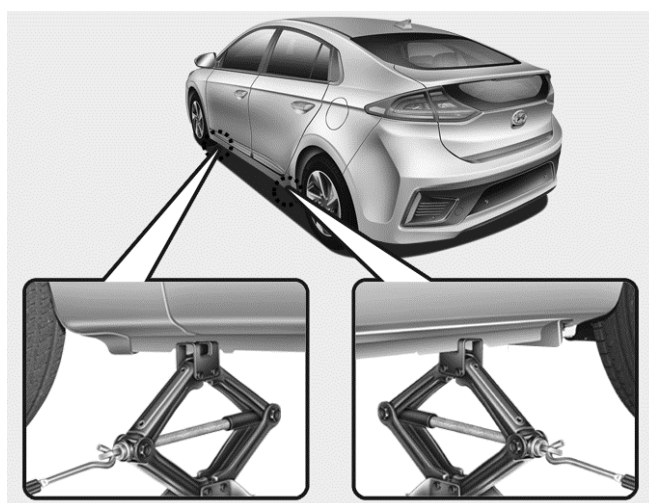



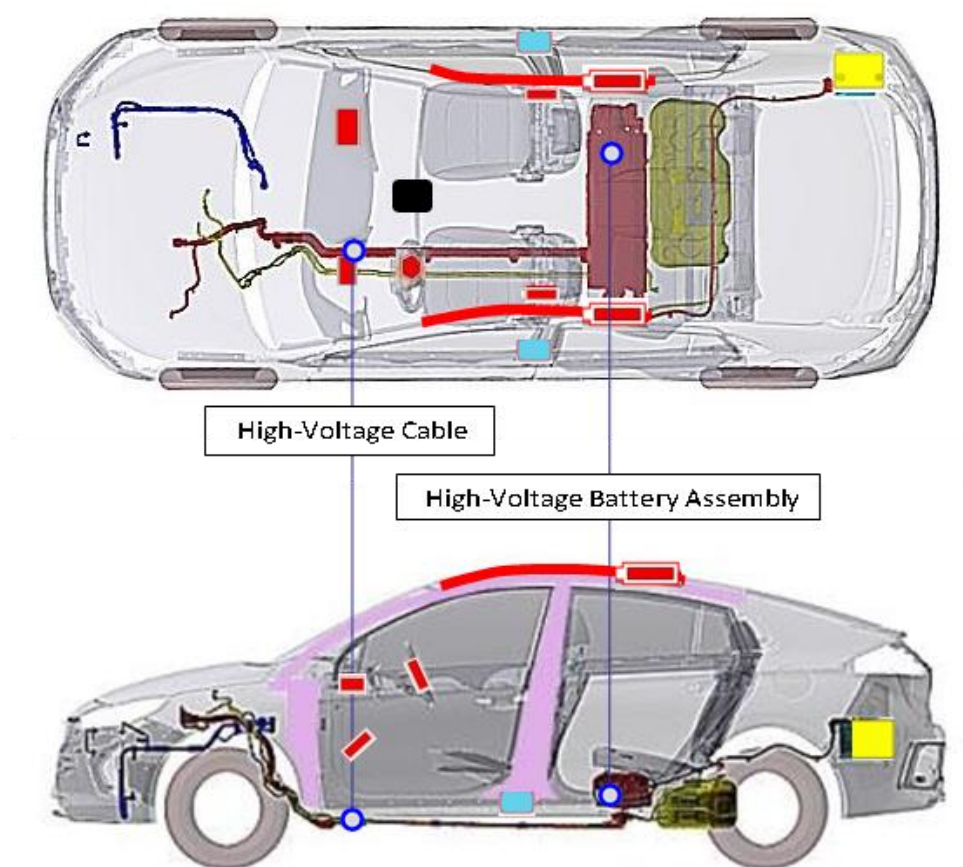

Use standard stabilisation (cribbing) points, as shown. Always be sure to connect to a structural member of the vehicle and avoid placing cribbing under high voltage cables, fuel lines and other areas not normally considered acceptable.



Extraction Tools and Procedure

When responding to an incident involving a IONIQ hybrid, we recommend that the first responders follow their organisation's standard operating procedures for assessing and dealing with vehicle emergencies. When the first responders cut the vehicle, they should always pay special attention to airbag system, orange colored high voltage cables and other high voltage components to avoid damage to parts which may increase the risks of explosion.



- | | | | |
|---|---|---|----------------------------------|
|  | Airbag & Gas inflator |  | EFD (Emergency Fastening Device) |
|  | Airbag |  | Airbag module |
|  | Gas inflator |  | 12V battery |
|  | Belt pre-tensioner
(Rear Seat Belt pre-tensioners are applied only general market) |  | Ultra (hot stamping) steel |

Submersion

Some emergency responses can involve a submerged vehicle. A IONIQ hybrid that is submerged does not have high-voltage component on the vehicle's body or framework. It is safe to touch the vehicle's body or framework if there is no severe damage to the vehicle, whether it is in water or on land.

In the event the vehicle is submerged or partially submerged, remove the vehicle from the water before attempting to disable the vehicle. Drain the water from the vehicle. Use one of the methods described in sections of page 22 ~ 26 to disable the vehicle.

⚠ WARNING

- If severe damage causes high-voltage components to become exposed, responders should take appropriate precautions and wear appropriate insulated personal protective equipment.
- Do not attempt to remove a safety plug while standing in the water.

Failure to follow any of these instructions may result in serious injury or death by electrocution.

Vehicle Fire

After Initial Emergency Response Procedures have been applied, Firefighting Procedures may begin. Hyundai recommends that each response team follow their own department's standard operating procedures for fighting vehicle fires in combination with the IONIQ Hybrid specific details that are covered in this section.

Firefighting Operations

If the high-voltage battery pack is either involved in or at risk of being involved in a fire in a IONIQ Hybrid, strict cautions must be taken while conducting firefighting operations due to following reasons:

- Lithium-ion Polymer batteries contain gel electrolyte that can vent, ignite, and produce sparks when subjected to temperatures above 150°C / 300°F.
- May burn rapidly with a flare-burning effect.
- Even after the high-voltage battery fire appears to have been extinguished, renewed or delayed fire can occur.
 - Use a thermal imaging camera to ensure the high voltage battery is completely cooled before leaving the incident.
 - Always advise second responders that there is a risk of the battery re-igniting.
 - Fire, submersion or a collision that has compromised the high voltage battery, always store it in an open area with no exposures within 15m / 50 feet.
- A burning battery could release hydrogen fluoride, carbon monoxide, and carbon dioxide gasses. Use NIOSH/MSHA approved full-face self-contained breathing apparatus (SCBA) with full protective gear.

Even if the high-voltage battery pack is not directly involved in a vehicle fire, approach the vehicle very carefully.

Extinguishers

- Small fires that high voltage battery is not involved : Extinguish fires using a ABC extinguisher for an electric fire.
- Fires that the high voltage battery is involved or the high voltage battery is heating : Extinguish fires using large and sustained amount of water to cool the high voltage battery. Do not extinguish fire with a small amount of water. Firefighters should not hesitate to pour large amounts of water on the vehicle.

High-Voltage (HV) Battery Damage & Fluid Leaks

The HV Battery assembly is enclosed in a sturdy metal case that is rigidly mounted to structural components of the vehicle. This construction helps prevent damage to the HV Battery assembly even in severe crashes. This section provides emergency responders with information regarding how to mitigate the severity of a damaged HV Battery assembly or gel electrolyte spill, however unlikely that might be.

- Cease all smoke, spark, flame activity around the vehicle.
- Electrolyte solution is a skin irritant.
- Do not touch or step on the spilled electrolyte.
- If electrolyte leak occurs, wear appropriate solvent resistant PPE and use oil, sand, or a dry cloth to clean up the spilled electrolyte. Be sure to adequately ventilate the area.

⚠ WARNING

Irritant Substance Risk!

- Internal components of HV Batteries are irritants and sensitizers.
- To avoid contact with these irritants and sensitizers wear positive pressure self-contained breathing apparatus (SCBA) and other personal protective equipment (PPE) designed for use with these types of hazards.

Failure to wear proper SCBA and PPE can result in serious injury or death.

- Electrolyte solution is an eye irritant – If contact with eyes, rinse with plenty of water for 15 minutes.
- Electrolyte solution is a skin irritant. Therefore, if there is contact with skin, wash off with soap.
- Electrolyte liquid or fumes that have come into contact with water vapours in the air will create an oxidized substance. This substance may irritate skin and eyes. In these cases, rinse with plenty of water and see a doctor immediately.

- Electrolyte fumes (when inhaled) can cause respiratory irritation and acute intoxication

Move to a well ventilated location for fresh air and wash mouth with water. See a doctor immediately.

Towing

When towing IONIQ hybrid vehicle, all wheels should be off the ground and not in contact with the road.

If emergency towing is necessary, we recommend having it done by an authorised Hyundai Dealer or a commercial tow-truck service. The use of wheel dollies or flatbed is recommended.

⚠ CAUTION

- Do not tow the vehicle backwards with the front wheels on the ground as this may cause damage to the vehicle.
- Do not tow with sling-type equipment. Use wheel lift or flatbed equipment.
- Never tow the vehicle with the front wheels on the ground (forward or backward), as this may cause damage to the vehicle.

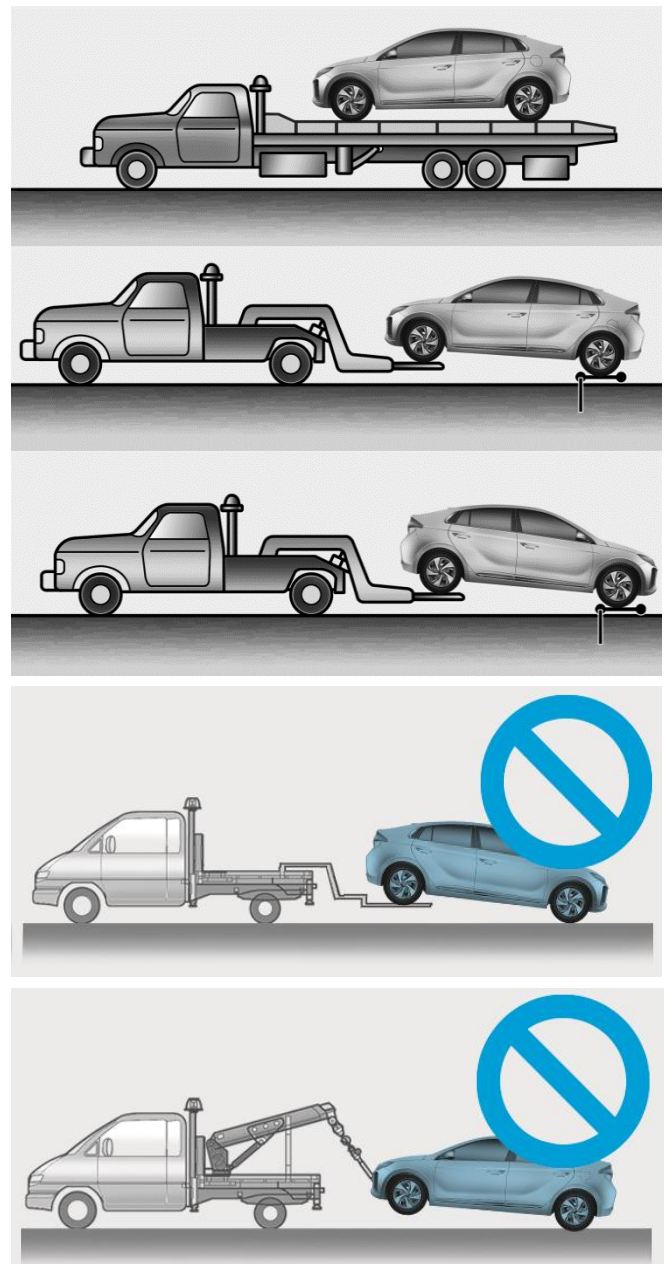

To Jump Start the Car – Standard 12 Volt Lead Acid

Battery

1. Make sure the booster battery is 12-volt.
2. If the booster battery is in another vehicle, do not allow the vehicles to touch.
3. Turn off all unnecessary electrical loads.
4. First connect one end of a jumper cable to the positive terminal of the discharged battery in the motor compartment, then connect the other end to the positive terminal on the booster battery.

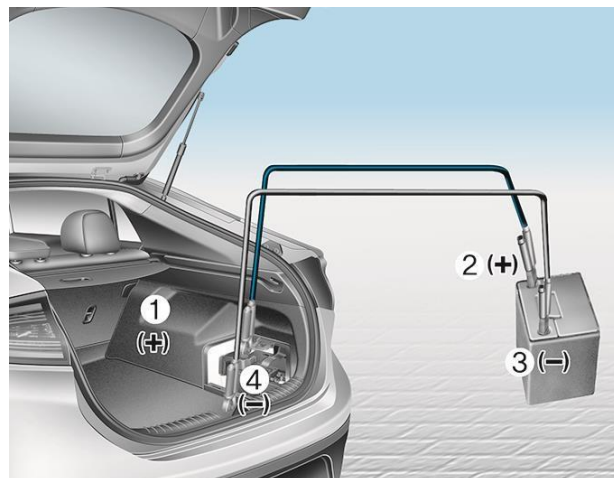

Proceed to connect one end of the other jumper cable to the negative terminal of the booster battery, then the other end to a solid, stationary, metallic point away from the battery (for example, the bonnet latch).

CAUTION

- Do not connect the cables to or near any part that moves when the vehicle is started.
- Do not allow the jumper cables to contact anything except the correct battery terminals or the correct ground.
- Do not lean over the battery when making connections.

5. Start the vehicle with the booster battery, then start the vehicle with the discharged battery.
6. After a few minutes, turn off both of the vehicles.
7. Remove the negative terminal cable first, and then remove the positive terminal cable. If the cause of your battery discharging is not apparent, we recommend that the system be checked by an authorised HYUNDAI Dealer or authorised HYUNDAI Service Agent.

To Jump Start the Car – 12 Lithium-ION Battery Applied from Model Year 2018

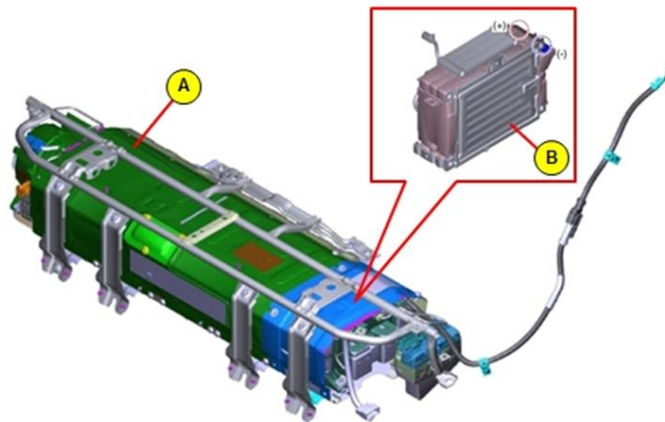

A: High voltage battery, B: 12V Li-ion auxiliary battery

When State of Charge of 12V auxiliary battery drops to 0%, there are 2 methods to start up the engine. One is pressing the '12V battery reset switch' and another is using a battery jumping cable. However, if the 12V auxiliary battery operates normally, battery protection system will activate to prevent the battery drain by shutting off the 12V power relay when SOC is between 0 and 10%.

Method 1

- 1)
Press the '12V Battery Reset switch' (Located at the left side of the steering wheel near the fuel door open switch) to reconnect the 12V battery.
- 2)
Start the vehicle within 15 seconds after pressing the '12V Battery Reset switch'.
- 3)
After starting vehicle (Indicator on), operate the vehicle safely outdoors in ready mode stopped and/or drive it for 30 minutes to charge the 12V battery fully.



If you do not start the vehicle immediately after pressing the '12V Battery Reset switch', the 12V battery power is automatically disconnected after few seconds to save the 12V battery from additional discharge. If the 12V battery is disconnected prior to starting the vehicle, press the '12V Battery Reset switch' again and then immediately start the vehicle as explained. Repeated use of the '12V Battery Reset switch' without a sufficient engine ON cycle (30 Min+) may cause over discharge of the 12V battery, which will prevent the vehicle from starting. If the 12V battery is over discharged to a point that the reset does not work, try to jump-start the vehicle.

To Jump Start the Car – 12 Lithium-ION Battery Applied from Model Year 2018

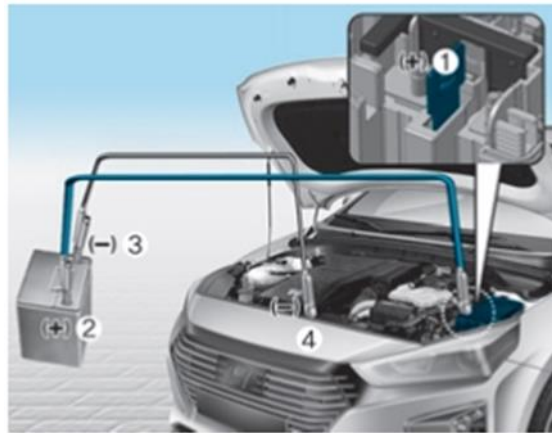

If the vehicle still does not have a functional 12V battery (Check if interior lights will not turn on) then you can try a jump start to the engine compartment jumper terminals using a 12V booster pack or jumper cables from another vehicle's 12V battery according to the following instructions.

⚠ CAUTION

- Do not connect the cables to or near any part that moves when the vehicle is started.
- Do not allow the jumper cables to contact anything except the correct battery terminals or the correct ground.
- Do not lean over the battery when making connections.

- 1) Position the vehicles close enough that the jumper cables will reach, but do not allow the vehicles to touch.
- 2) Avoid fans or any moving parts in the engine compartment at all times, even when the vehicles are turned off.
- 3) Turn off all electrical devices such as radios, lights, air conditioning, etc. Put the vehicles in P (Park) and set the parking brake. Turn both vehicles OFF.

- 4) Connect the jumper cables in the exact sequence shown in the illustration. First connect one jumper cable to the red, positive (+) jumper terminal of your vehicle (1).
- 5) Connect the other end of the jumper cable to the red, positive (+) battery/jumper terminal of the assisting vehicle (2).
- 6) Connect the second jumper cable to the black, negative (-) battery/chassis ground of the assisting vehicle (3).
- 7) Connect the other end of the second jumper cable to the black, negative (-) chassis ground of your vehicle (4). Do not allow the jumper cables to contact anything except the correct battery or jumper terminals or the correct ground. Do not lean over the battery when making connections.
- 8) Press the 12V Battery Reset switch.
- 9) Start the engine of the assisting vehicle and let it run for a few minutes.
- 10) Start your vehicle as soon as possible. After starting vehicle (indicator on), operate the vehicle safely outdoors in ready mode stopped and/or drive it for 30 minutes total to charge the 12V battery fully.

CAUTION

When 12V auxiliary battery charge is required, it is possible to charge it using the 12V battery reset switch, battery jumping cable or 12V battery charger. However, when using the battery charger used for charging the lead-acid battery, charge voltage range must be kept in between 14V~14.8V. If not, 12V auxiliary battery may not be charged. But be careful not to allow the charge voltage to exceed 14.8V in order to prevent the reduction of Li-ion battery life.

HYUNDAI HELP LINE
0800 HYUNDAI (498 632)